

## Basal Ganglia

# The Wonders of the Basal Ganglia

by Mackenzie Breton and Laura Strong /// <https://kin450-neurophysiology.wikispaces.com/Basal+Ganglia>

### Introduction

The basal ganglia are a group of nuclei located beneath the cerebral hemisphere. Main components include the caudate nucleus, putamen, globus pallidus internus, globus pallidus externus, substantia nigra reticula, substantia nigra compacta and the subthalamic nucleus. Each of these structures are involved in a loop of fiber connections from the cerebral cortex to the thalamus and back to the cerebral cortex. These neuronal connections contribute to the initiation or inhibition of motor systems.

There is also evidence that the basal ganglia are involved in cognitive and emotional functions. Although, there is still a lot of unknown about the nature of the basal ganglia and its function, understanding the anatomy and physiology of the structure aids in understanding it's importance. It is also helpful to look at the negative symptoms that transpire during illnesses related to the dysfunction of the basal ganglia, such as in Parkinson's and Huntington's disease. When there is dysfunction in the basal ganglia the control and initiation of movements are most definitely affected.

### Functional anatomy review

The basal ganglia consists of the **caudate nucleus, the putamen, and the globus pallidus**. Together the putamen and the globus pallidus are called the lentiform pallidus because of their extremely small shape. The putamen and the caudate nucleus are similarly built and collectively referred to as the striatum.

The caudate nucleus plays a key role in the brain's learning and memory system. It is located medial to the internal capsule and sits along the thalamus. It forms a "C" shape with a bulkey caput (head) and a thin cauda (tail). Together, with the putamen, the striatum is considered to be the receiving part of the basal ganglia.

The putamen, sometimes considered to be the same structure as the caudate nucleus as well as the lateral component of the lentiform pallidus, is responsible for regulating movement and various types of learning. It is located inferior to the caudate nucleus and is attached to the bulkey caput.

The globus pallidus is the medial part of the lentiform pallidus and is involved in regulating voluntary movements. It consists of two parts: the globus pallidus externa and the globus pallidus interna. They receive input from the caudate and putamen and are in communication with the subthalamic nucleus.

## Inputs and Outputs of the Basal Ganglia

Inputs to the basal ganglia enter through the striatum, the major input of the entire basal ganglia system. Outputs leave from the basal ganglia through the internal segment of the globus pallidus and the substantia nigra pars reticulata. Both the globus pallidus and the substantia nigra are critical components of the basal ganglia core.

It is important to note that there are numerous forms of complex excitatory and inhibitory connections within the basal ganglia. These connections utilize several different neurotransmitters. Additionally, it appears that present in the basal ganglia are varied pathways **designed for different functions**. These functions include: general motor control, eye movements, emotional functions, and cognitive functions.

### *Inputs*

The primary input to the basal ganglia is the striatum, which travels from the cerebral cortex. Cortical inputs to the striatum are classified as “excitatory.” This means that when cortical neurons are excited, their output will increase, and each successive output that they receive while in an excited state serves to significantly raise their output. Cortical inputs utilize glutamate as their neurotransmitter. Glutamate is the principle excitatory neurotransmitter in the brain.

Another important input to the basal ganglia is from the substantia nigra pars compacta. This is an unusual pathway, known as a **dopaminergic nigrostriatal pathway**, as it is excitatory to some cells and inhibitory to other cells within the striatum. It is one of the four primary dopamine pathways in the brain and is especially involved with the production of movement.

While there are many inputs to the basal ganglia, there are several more important ones worth mentioning. For example, another significant source of input comes from a subpopulation of striatal neurons found in patches, known as striosomes. The striatum also receives excitatory inputs from intralaminar nuclei, which can be located within the internal medullary lamina of the thalamus. There are also serotonergic inputs that travel to the basal ganglia from the raphe nuclei of the brainstem.

These inputs can be summarized in the following chart:

<b>SOURCE OF INPUT</b>	<b>NEUROTRANSMITTER</b>
<b>Cerebral Cortex</b>	Glutamate
<b>Substantia Nigra Pars Compacta</b>	Dopamine
<b>Intralaminar Nuclei (Within the Thalamus)</b>	Glutamate
<b>Raphe Nuclei of Brainstem</b>	Serotonin

## *Outputs*

The basal ganglia outputs develop out of the internal segment of the globus pallidus as well as from the substantia nigra pars reticulata. Both sources are tremendously important for motor control. For example, the substantia nigra pars reticulata (SNr) seems to transmit information about the head and the neck, while the internal segment of the globus pallidus conveys information about the rest of the body. Both of these **output pathways are inhibitory and are facilitated by the neurotransmitter GABA.**

The main output pathways lead to the ventral lateral and ventral anterior nuclei of the thalamus by means of the thalamic fasciculus. The more posterior components of the thalamic fasciculus carry cerebellar outputs to the posterior VL, while the more anterior components of the thalamic fasciculus carry outputs to anterior portion of the VL. It is also important to note that thalamic neurons transmit information from the basal ganglia to the entire frontal lobe. However, information specific for motor control mainly travels to the premotor cortex, the supplementary motor area, and the primary motor cortex.

Outputs from the basal ganglia, though, also travel to other thalamic nuclei. For instance, outputs travel from the intralaminar nuclei, which projects back to the striatum and the mediodorsal nucleus (which is primarily involved in limbic pathways). Additionally, the internal segment of the globus pallidus and the substantia nigra pars reticulata project to the pontomedullary reticular formation. This exerts influence on the descending reticulospinal tract. The substantia nigra pars reticulata also projects to the superior colliculus, influencing tectospinal pathways.

In sum, one sees how the basal ganglia both the lateral motor systems, which include the lateral corticospinal tract and the medial motor systems (which is further divided into the reticulospinal and tectospinal tracts).

## **Direct and Indirect Pathways**

There are **two predominant pathways from input to output nuclei through the basal ganglia**. The direct pathway travels from the striatum directly to the internal segment of the globus pallidus or the substantia nigra pars reticulata. The indirect pathway takes a detour from the striatum, first to the external segment of the globus pallidus and then goes to the subthalamic nucleus, before finally reaching the internal segment of the globus pallidus or the substantia nigra pars reticulata.

The effect of **excitatory input from the cortex through the direct pathway results in excitation of the thalamus, which in turn facilitates movements through its connection with the motor and premotor cortex.**

For the **indirect pathway there is an inhibition of the thalamus, resulting in inhibition of movements through connections back to the cortex.**

Striatal projection neurons for both pathways are made up of inhibitory spiny neurons containing the neurotransmitter GABA. In the direct pathway, spiny striatal neurons project to the internal segment of the globus pallidus and contain the peptide substance P in addition to GABA. Output neurons from the internal globus pallidus and substantia nigra pars reticulata to the thalamus are also inhibitory and contain GABA. In the indirect pathway, striatal neurons project to the external segment of the globus pallidus and contain the inhibitory neurotransmitter GABA, plus the peptide enkephalin. Neurons of the external globus pallidus, in turn, send inhibitory GABAergic projections to the subthalamic nucleus. Excitatory neurons in the subthalamic nucleus containing glutamate then project to the internal segment of the globus pallidus and to the substantia nigra pars reticulata. As in the direct pathway, outputs from these nuclei to the thalamus are inhibitory and are mediated by GABAergic neurotransmission.

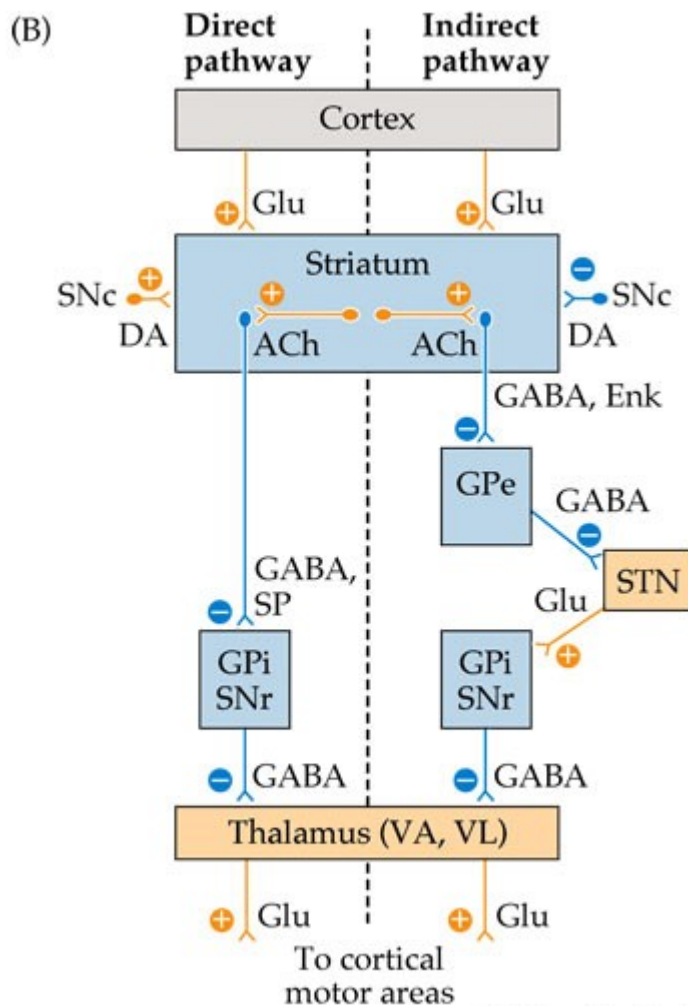

## Parallel Basal Ganglia Pathways

The basal ganglia contain four parallel channels of information processing for different functions. These include the motor, oculomotor, prefrontal and limbic channels. Each channel projects to different regions of the frontal lobe and uses their own slightly different pathways to get there. The motor, oculomotor and prefrontal channels are often grouped together as the dorsal striatal pathways and the limbic channel involves ventral striatal pathways.

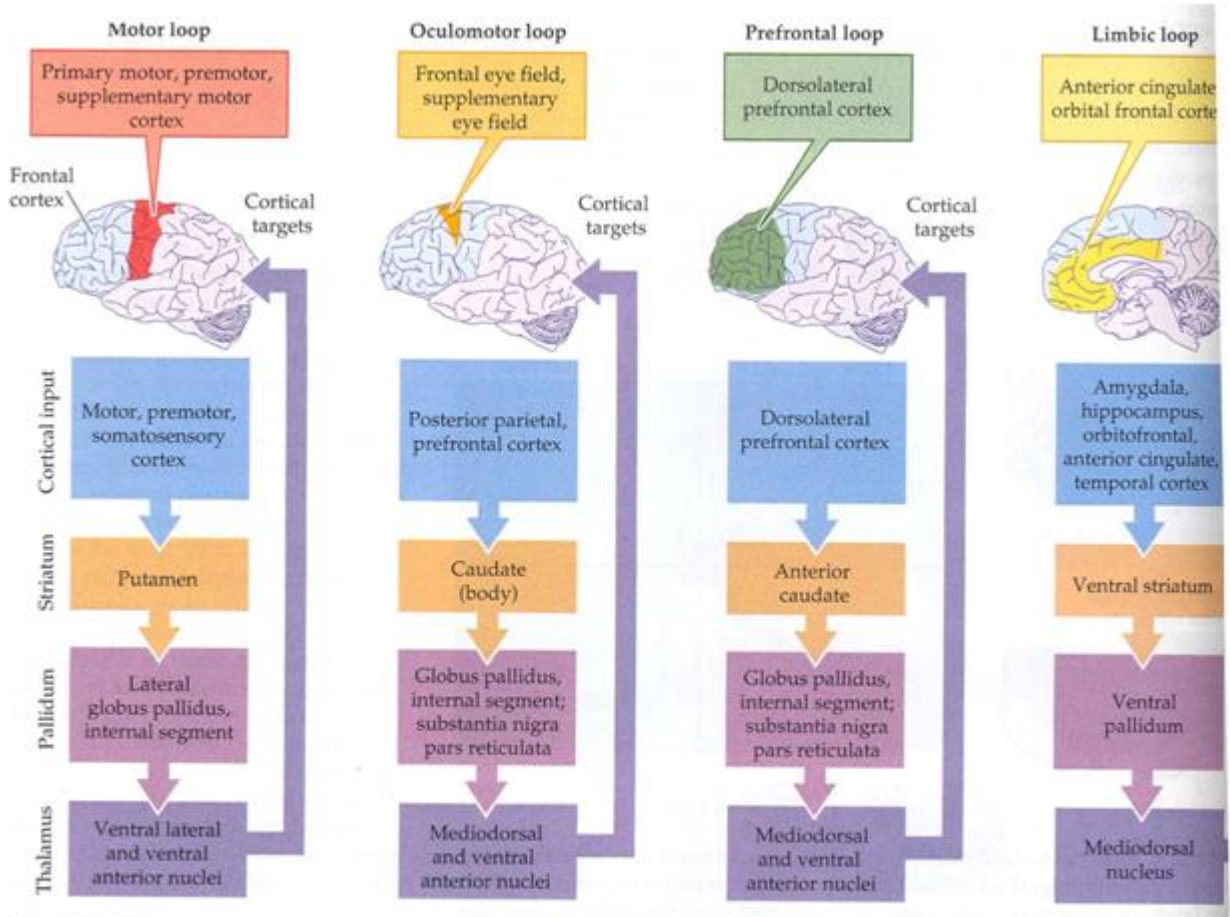

Sources of Critical Input	Basal Ganglia Input Nuclei	Basal Ganglia Output Nuclei	Thalamic Relay Nuclei	Cortical Targets of Output
<b>MOTOR CHANNEL</b> (somatosensory cortex; primary motor cortex; premotor cortex)	Putamen	GPi, SNr	VL, VA	Supplementary motor area; premotor cortex; primary motor cortex
<b>OCULOMOTOR CHANNEL</b> (posterior parietal cortex; prefrontal cortex)	Caudate, body	GPi, SNr	VA, MD	Frontal eye fields; supplementary eye fields
<b>PREFRONTAL CHANNEL</b> (posterior parietal cortex; premotor cortex)	Caudate, head	GPi, SNr	VA, MD	Prefrontal Cortex
<b>LIMBIC CHANNEL</b> (temporal cortex; hippocampus; amygdala)	Nucleus accumbens; ventral caudate; ventral putamen	Ventral Pallidum; GPi; SNr	MD, VA	Anterior cingulate; orbital frontal cortex

### Functions of the basal ganglia

- **Initiation of self-initiated movements** or internally generated movements, especially when initiated movements are slow.
- **Disinhibit areas** of the motor system thus allowing movement to occur, this is done by **turning off the ever present postural activity** allowing movement to occur.
- Involved in **sequencing movement fragments**, complex motor strategies selectively activate some movements and suppress others. (i.e. as in repetitive movement of walking)
- Scaling movement parameters.
- Plays a role in sensorimotor integration and sensory gating.
- Role in cognitive and emotional functions.

## Dysfunction in the Basal Ganglia

Usually when there is dysfunction in the basal ganglia it results in motor symptoms. These symptoms can be due to loss of neuronal activity and abnormally increased neuronal activity. Most diseases of the basal ganglia impede the initiation part of movement which causes akinesia.

There are **two broad groups** of basal ganglia diseases. The **first** are the diseases characterized by akinesia and rigidity and likely caused by a loss of dopamine, and the **second** are the diseases characterized by dyskinesia and likely caused by dopaminergic hyperactivity. The three major diseases that effect the basal ganglia are **Parkinson's Disease, Huntington's Disease, and Tourette's Syndrome.**

### *Parkinson's Disease*

Parkinson's Disease is characterized by **akinesia, rigidity, tremor, and dopamine loss**. Someone with Parkinson's may appear to have short steps due to bradykinesia, a lack of arm movement while walking, loss of facial expression, and increased salivation as a result of disturbances in the autonomic nervous system. Tremors are most pronounced at rest. The rigidity is caused by descending influences that increase the excitability of the motoneurons so that they fire continuously. Symptoms of Parkinson's are most likely caused by the increased firing of neurons in the subthalamic nucleus.

### *Huntington's Disease*

Huntington's disease is characterized by **dyskinesia and dopaminergic hyperactivity** as well as rapid, jerky, involuntary movements of the face, arms, and legs. It is a dominantly inherited disease and usually appears in the 40s.

It is thought that in earlier stages of the disease there is a reduction in inhibition of the GPe neurons and therefore an increased inhibition of the subthalamic nucleus. This leads to the excitation of the GPi and the reduced inhibition of the thalamocortical neurons which possibly leads to the choreatic movements seen in Huntington's disease. In the later stages the striatal neurons projecting to the GPi die which leads to reduced inhibition of GPi and increased inhibition of thalamocortical neurons which explains why bradykinesia doesn't develop until the later stages of the disease. Another possibility is that the loss of GABAergic inhibition in the substantia nigra causes a dopaminergic hyperactivity in the striatum.

### *Tourette's Syndrome*

Tourette's syndrome is a neurological disorder that is characterized by **uncontrollable movements called tics**. Some other signs and symptoms include but are not limited to eye-blinking, eye-rolling, wrinkling or twitching the nose, poking or picking the nose, spitting, flipping or twirling hair, rolling the head, cracking body parts, compulsively touching, bending or jumping, tongue clicking, humming, whistling, grunting, and

repetition of words. Contrary to popular belief, **only 15% of people with TS ever experience coprolia, which is the uncontrollable use of swears or other derogatory terms.**

The tics associated with Tourette's syndrome originate from signals sent by the basal ganglia. The basal ganglia include the putamen, the caudate nucleus, and the amygdala. These structures are responsible for unconscious movements, impulsiveness, and inhibition. Although the exact cause of TS is unknown, neurons are thought to play a crucial role. Specifically dopamine appears to be the main neurotransmitter involved in TS. When functioning properly it helps regulate the release of other neurotransmitters and hormones.

## **Conclusion**

Without the basal ganglia, humans could not function in remotely the same way as we do today. The basal ganglia, although they are just a **collection of subcortical nuclei**, allow us to integrate feeling and movement, suppress unwanted motor behaviors, enhance motivation, and shift to smooth or fine motor behavior. As scientists learn more and more about the basal ganglia we are better able to understand basal ganglia related diseases such as Parkinson's, Huntington's, and Tourette's.

## **Key Terms**

Caudate nucleus  
Putamen  
Globus pallidus  
Substantia nigra  
Subthalamic nucleus  
Lentiform nucleus  
Striatum  
Cerebral cortex  
Intralaminar thalamic nuclei  
Dopamine  
Acetylcholine  
Glutamate  
Thalamus  
Ventral anterior nucleus  
Ventrolateral nucleus  
Intralaminar nucleus  
Prefrontal cortex  
Reticular formation  
Akinesia  
Afferent  
Efferent



## Questions

### *Multiple Choice Questions*

The corpus striatum is composed of:

- a) Caudate nucleus, putamen, globus pallidus
- b) Substantia nigra, subthalamic nucleus
- c) Caudate nucleus, substantia nigra, subthalamic nucleus
- d) Globus pallidus externus, globus pallidus internus
- e) Substantia nigra reticula, substantia nigra compacta, putamen

The neurotransmitters involved in the internal circuitry of the basal ganglia include:

- a) GABA
- b) Glutamate
- c) Dopamine
- d) Serotonin
- e) A,B and C
- f) A and B
- g) All of the above

Projection components of the basal ganglia include:

- a) Visual and vestibular cortex
- b) Primary motor cortex
- c) Premotor areas
- d) Supplementary motor areas
- e) Limbic system
- f) Association areas
- g) All of the above
- h) D,E and F
- i) B,C,D and E

Which of the structures involved in the indirect pathway utilize the neurotransmitter GABA?

- a) Cortical cells
- b) Striatal cells
- c) Globus pallidus externus
- d) Subthalamic nucleus
- e) Globus pallidus internus
- f) Substantia nigra
- g) All of the above
- h) B,C,E and F

### *True/False*

- (T/F) Nearly all incoming information enters the basal ganglia through the striatum.  
(T/F) Stimulation of the indirect pathway leads to suppression of movement.  
(T/F) Outputs of the basal ganglia are primarily through the globus pallidus internus and the substantia nigra reticula.  
(T/F) The basal ganglia receives excitatory information from widespread regions of the cortex.  
(T/F) The basal ganglia has direct connections with spinal cord.

### *Short Answer*

- 1) List the major inputs of the basal ganglia, where they project, as well as the major neurotransmitters used.
- 2) What are the four main channels through the basal ganglia?
- 3) Diagram the direct and indirect pathways that either allow or inhibit movement.
- 4) Explain how administering dopa to treat Parkinson's disease works.

### **References**

Bear, Mark F.; Connors, Barry W.; Paradiso, Michael A. *Neuroscience Exploring the Brain*. Pennsylvania: Lippincott Williams & Wilkins, 2001. Print.

Blumenfeld, Hal. *Neuroanatomy through Clinical Cases*. Massachusetts: Sinauer Associates, Inc, 2002. Print.

Brodal, Per. *The Central Nervous System: Structure and Function*. New York: Oxford UP, 2004. Print.

Leckman, J.F., & Cohen, D. J. *Tourette's Syndrome: Tics, Obsessions, Compulsions*. Canada: John Wiley & Sons. Print.

Martin, John H. *Neuroanatomy Text and Atlas*. USA: McGraw-Hill, 1996. Print.

Mori, S; Stuart, D.G.; Wiesendanger, M. *Brain Mechanisms for the Integration of Posture and Movement*. Amsterdam: Elsevier, 2004. Print.

Sheperd, Gordon M. *The Synaptic Organization of the Brain*. New York: Oxford UP, 2004. Print